

Gen. 3 Automotive MOSFET

Excellent Figure-of-Merit & Dual-Side Cooling

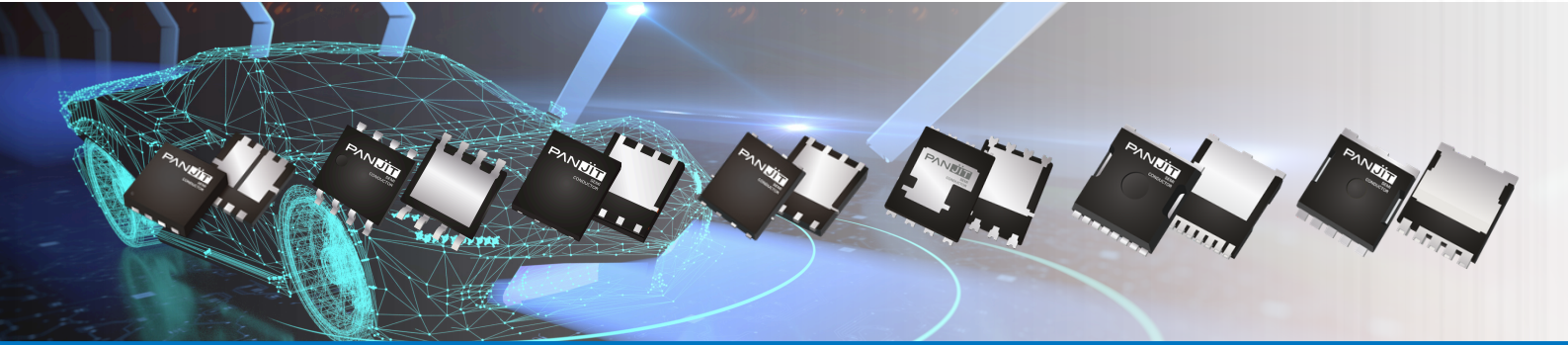

PANJIT’s third-generation Shielded-Gate Trench (SGT) MOSFETs are engineered for high-frequency DC/DC converters and automotive-grade reliability. Qualified to AEC-Q101 standards and rated for junction temperatures up to 175 °C, these devices are ideal for demanding applications such as electric power steering (EPS), onboard DC/DC converters, and other critical power control systems. Featuring an outstanding figure of merit ($R_{DS(on)} \times Q_g$), excellent avalanche capability, and superior switching performance, PANJIT’s SGT MOSFETs support compact, efficient, and thermally robust designs across a variety of power topologies, including LLC, PSFB, synchronous buck, and boost converters. Offered in a broad range of package options, with highlighted solutions such as dual-side cooling packages for enhanced thermal performance and side wettable flank packages to support Automated Optical Inspection (AOI) and high-reliability automotive assembly, these MOSFETs enable flexible, robust, and manufacturable system designs.

► Key Features

- Third-generation shielded-gate trench technology
- Extremely low figure of merit ($FOM=R_{DS(on)} \times Q_g$)
- Optimized for fast switching and minimal voltage spiking
- AEC-Q101 qualified and PPAP-capable

► Target Applications

- Electric power steering
- Smart fuse box
- Car seat
- DC/DC converter

► Automotive-Grade MOSFET Roadmap

	2026	2027	2028
150 V			SGT Specifications TBD
100 V	SGT Standard Level $R_{DS(on)}$: Lowest @ 1.3 mΩ Low FOM ≤135 Package: TOLL		
80 V		SGT Standard Level Specifications TBD	
60 V		SGT Specifications TBD	
40 V	SGT Standard Level $R_{DS(on)}$: Lowest @ 0.49 mΩ Low FOM ≤65 Package: DFN5060SW-8L		SGT LogicLevel Package: DFN5060SW-8L

► Performance Comparison

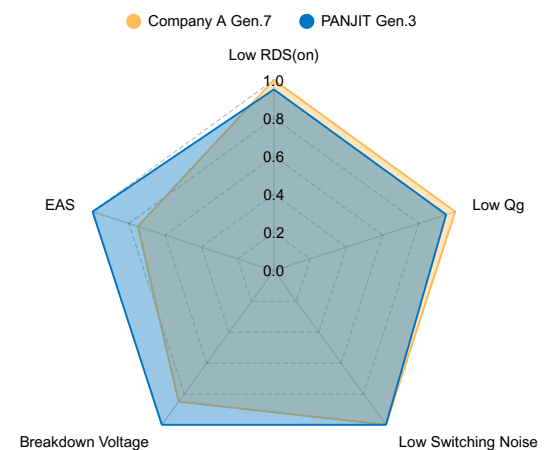

➤ Block Diagram of the Buck-Boost Converter

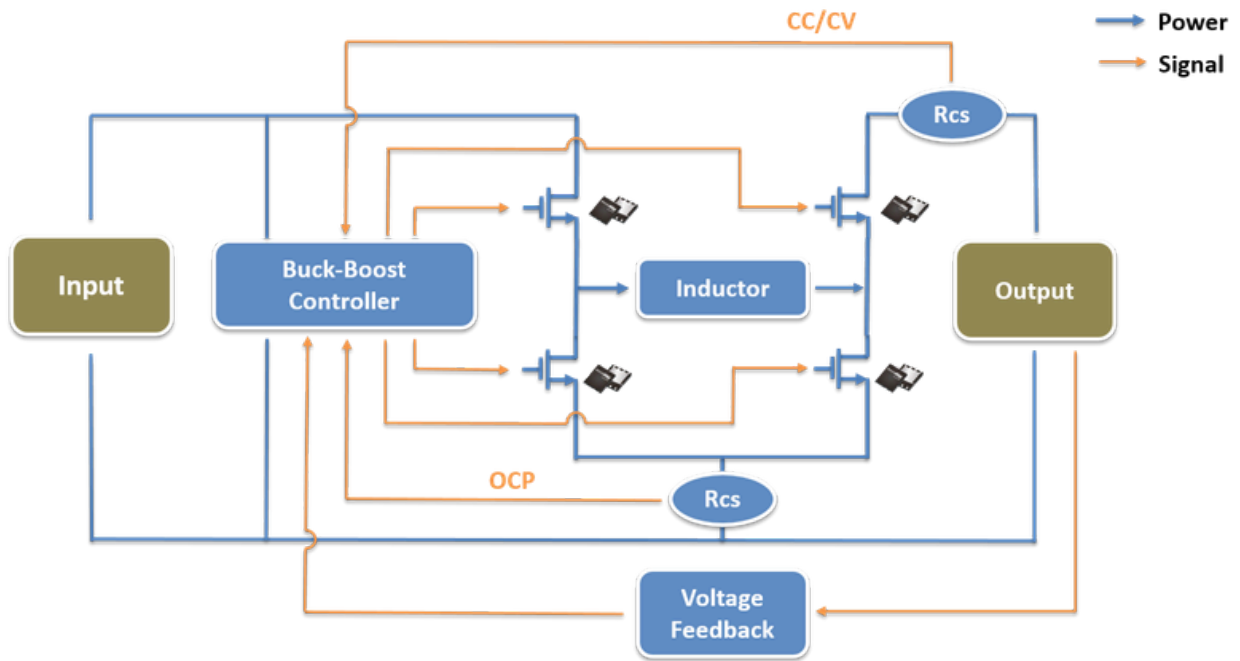

➤ Output Power vs. Efficiency Performance Comparison

300 W Buck (24 V to 12 V/25 A)
400 KHz operating frequency

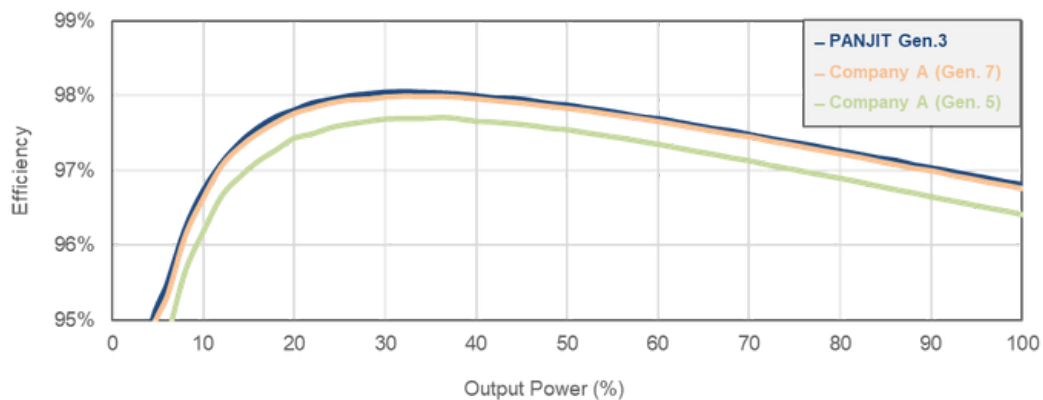

288 W Boost (12 V to 24 V/12 A)
400 KHz operating frequency

